

N-PRCMタイプ

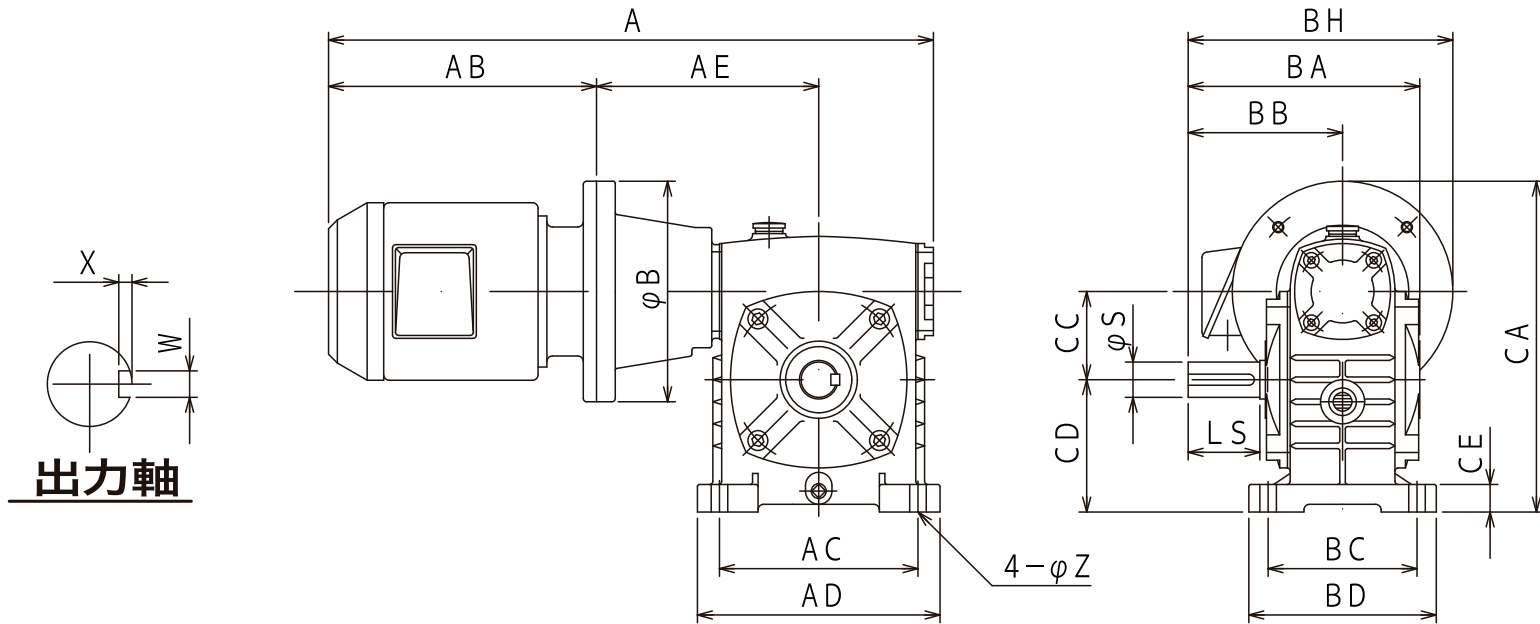

型番	使用モータ (W)	速比	A	AB	AE	BA	B	BH	CA	AC	AD	BB	BC	BD	CC	CD	CE	Z	出力軸				重量 (kg)	油量 (L)
																			LS	S	W	X		
12	200	10-60	396	196	130	145	160	175	210	110	140	95	95	120	50	80	15	11	40	17	5	3	19	0.3
15	200	50-60	406	196	135	165	160	190	230	120	150	110	105	130	60	90	20	11	50	22	6	3.5	22	0.4
	400	10-40	445	226	144																			
18	400	50-60	483	226	163	195	160	210	255	150	190	130	115	150	70	105	22	15	60	28	8	4	29	0.7
	750	10-40	526	255	177		200	230	275															
22	750	40-60	546	255	187	210	200	240	300	180	220	140	135	170	80	120	25	15	65	32	10	5	38	1.2
	1500	10-30	587	286	197																			
25	1500	50-60	645	286	227	260	200	270	350	220	270	170	155	190	100	150	25	15	75	38	10	5	68	2.9
	2200	10-40	702	317	253		250	295	375															
30	2200	40-60	749	317	279	285	250	315	425	260	320	190	180	230	120	180	30	18	85	45	14	5.5	104	4.8
	3700	10-30	770	338																				
35	3700	40-60	809	338	299	310	250	335	475	290	350	210	200	250	135	215	30	18	95	55	16	6	141	5.2
	5500	10-30	879	376	331		300	360	500															